

HA20 RTJ



PERFORMANCE & EASE OF USE

- > Best lifting speed of 48 sec.
- > Industry leading working envelope with an outreach of 12.2 m
- > Fully proportional and simultaneous movements
- > Ease of transport

EXCELLENT ROBUSTNESS

- > Rugged hoods with ergonomic handle
- > Long lasting structural design

MINIMIZED TOTAL COST OF OWNERSHIP

- > Haulotte Activ'Screen (on board diagnostic)
- > Haulotte Stop Emission System: automatically turns the engine off & on
- > Exclusive modular basket with upper control box cover and tool tray
- > Easy access to all components



HA20 RTJ

ROUGH TERRAIN ARTICULATING BOOMS

TECHNICAL DATA

HA20 RTJ

Working height	20.6 m
Platform height	18.6 m
Horizontal outreach	12.2 m
Up and over clearance	8.4 m
Lift capacity	230 kg (2 pers.)
F x G Platform size	1.83 x 0.8 m
A Length - stowed	8.8 m
B Width	2.42 m
Height - stowed	2.51 m
H Storage / transport length	6.5 m
C Storage / transport height	2.93 m
Vertical jib rotation	140° (+ 60° / - 80°)
Platform rotation	180° (+ 90° / - 90°)
Turntable rotation	355° non continuous
Tailswing	14.2 cm
D Wheelbase	2.45 m
E Ground clearance	38 cm
Tilt	5°
Drive speed	0.8 - 5 km/h
Gradeability	45 %
Tyres - solid rough terrain	850 x 340 mm
Turning radius - outside	4.5 m
Power source	Kohler 36.5 kW (Stage 5), Perkins 36.5 kW (LRC), Kubota 36.5 kW (China 4)
Weight	9 300 kg

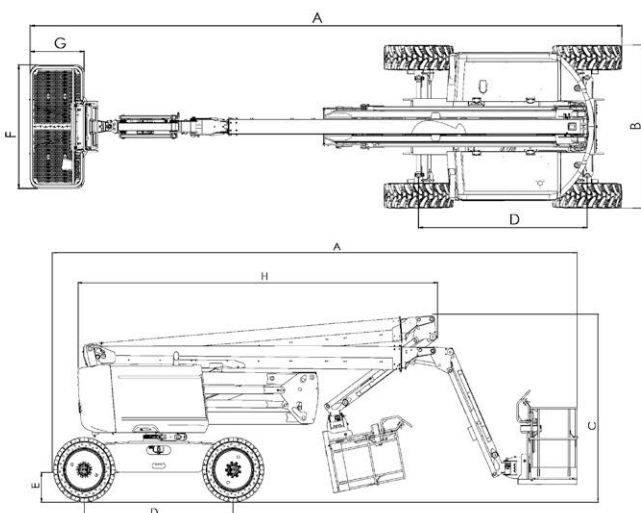

STANDARD EQUIPMENT

- > Haulotte Activ'Screen
- > Haulotte Stop Emission System
- > Universal telematics plug
- > 4 wheel drive, 2 wheel steer
- > 4 simultaneous movements for maximum productivity
- > Permanent limited slip differential
- > Upper control box protection cover and tool tray in ultra-solid plastic
- > Modular standard basket 1.83 m x 0.80 m, drop bar entry gate
- > AC power to platform 110 / 230 V
- > Swing out engine tray for ease of maintenance
- > Sound and light alarm for tilt and load
- > Rotating beacon
- > Travel alarm
- > Hour meter
- > 12 V battery / electrical control system
- > Engine pre-heater with light indicator
- > Low fuel level indicator (upper control box)
- > Electric pump system and emergency descent

OPTIONS AND ACCESSORIES

- > Haulotte Activ'Shield Bar 2.0
- > Non-marking tires
- > Large modular basket 2.44 m x 0.91 m
- > Power to platform 110 / 230 V (with or without circuit-breaker 30 mA)
- > Air-line to platform 6.5 mm inner diameter
- > Lateral swing door entry gate
- > Hydraulic generator Dynaset 3.5 Kw
- > Biodegradable hydraulic oil
- > Hot weather kit: hydraulic oil cooler + hydraulic oil
- > Cold weather kit
- > Glazier pack
- > Flashing light
- > 55 W working light

